

CD-45GV-50, CD-45G-50-PRO SPECIFICATIONS

- OZONE OUTPUT (+/-10%).....45 g/hr
- FLOW RATE (max).....30 scfh (14.1 lpm)
- CONCENTRATION.....4.0 % weight
- POWER REQUIREMENTS.....230 VAC, 50 Hz, 1Ø, 8 Amp*
- COOLING WATER
 - FLOW.....0.2 gpm (0.8 lpm)
 - INLET TEMPERATURE**.....50°F – 90°F (10°C – 32°C)
 - INLET PRESSURE.....15 – 40 psi (100 – 270 kPa)
- HEAT REJECTION..... 4550 BTU/hr (1.3 kW)
- WEIGHT..... 175 lb (79 kg)
- LOCATION REQUIREMENTS***
 - MOUNTING..... FLOOR OR WALL MOUNT IN A CLEAN, PROTECTED AREA USING BRACKETS PROVIDED.
 - AMBIENT TEMPERATURE... 40°F - 100°F (5°C – 38°C)
 - VENTILATION..... 6 AIR CHANGES PER HOUR (MIN)

* STEADY STATE CURRENT. START-UP CURRENT WILL MOMENTARILY EXCEED THIS VALUE. 15A BREAKER RECOMMENDED.

** POTABLE WATER MAY BE USED FOR COOLING. SPECIFIED OZONE OUTPUT IS AT 70°F. GENERATOR EFFICIENCY AND LIFE WILL BE IMPROVED WITH WATER INLET TEMPERATURES OF 80°F OR LESS.

*** PROTECTION FROM WEATHER MUST BE PROVIDED FOR OUTDOOR INSTALLATIONS. OPERATING OUTSIDE OF THE RECOMMENDED TEMPERATURE RANGES MAY RESULT IN DAMAGE NOT COVERED UNDER THE MANUFACTURER'S WARRANTY.

FEATURES

- PROTECTION FROM
 - LOW VACUUM
 - HIGH VACUUM
 - PRESSURE LOSS
 - WATER BACKFLOW
 - OZONE CELL OVERHEAT
 - COMPRESSED AIR OVERHEAT
 - INLET AIR TEMPERATURE
- 12 VDC CONTROL SYSTEM POWERED BY FUSE PROTECTED CLASS 2 POWER SUPPLY
- BUILT-IN 20 AMP BREAKER ON MAIN POWER CIRCUIT
- DURABLE CERAMIC DIELECTRICS
- SELF REGULATED HIGH FREQUENCY OZONE POWER SUPPLIES
- POWDERCOATED STEEL ENCLOSURE
- OXYGEN CONCENTRATOR
 - OXYGEN OUTPUT..... 30 CFH
 - DEWPOINT..... -73°C
 - OXYGEN PURITY..... 90% +/-5%
 - SOUND LEVEL..... 56 DBA @ 1 METER
 - RESPONSE TIME..... 2 MIN. FROM INITIAL STARTUP TO ATTAIN MAXIMUM PURITY
 - COMPRESSORS..... DUAL GAST 1/3 HP OIL-LESS PISTON
- OUTPUT CONTROL:
 - GV MODEL: OFF, LOW, MEDIUM, HIGH; SWITCH ON FRONT PANEL
 - PRO MODEL: 0-100%; 4-20mA FROM EXTERNAL CONTROLLER

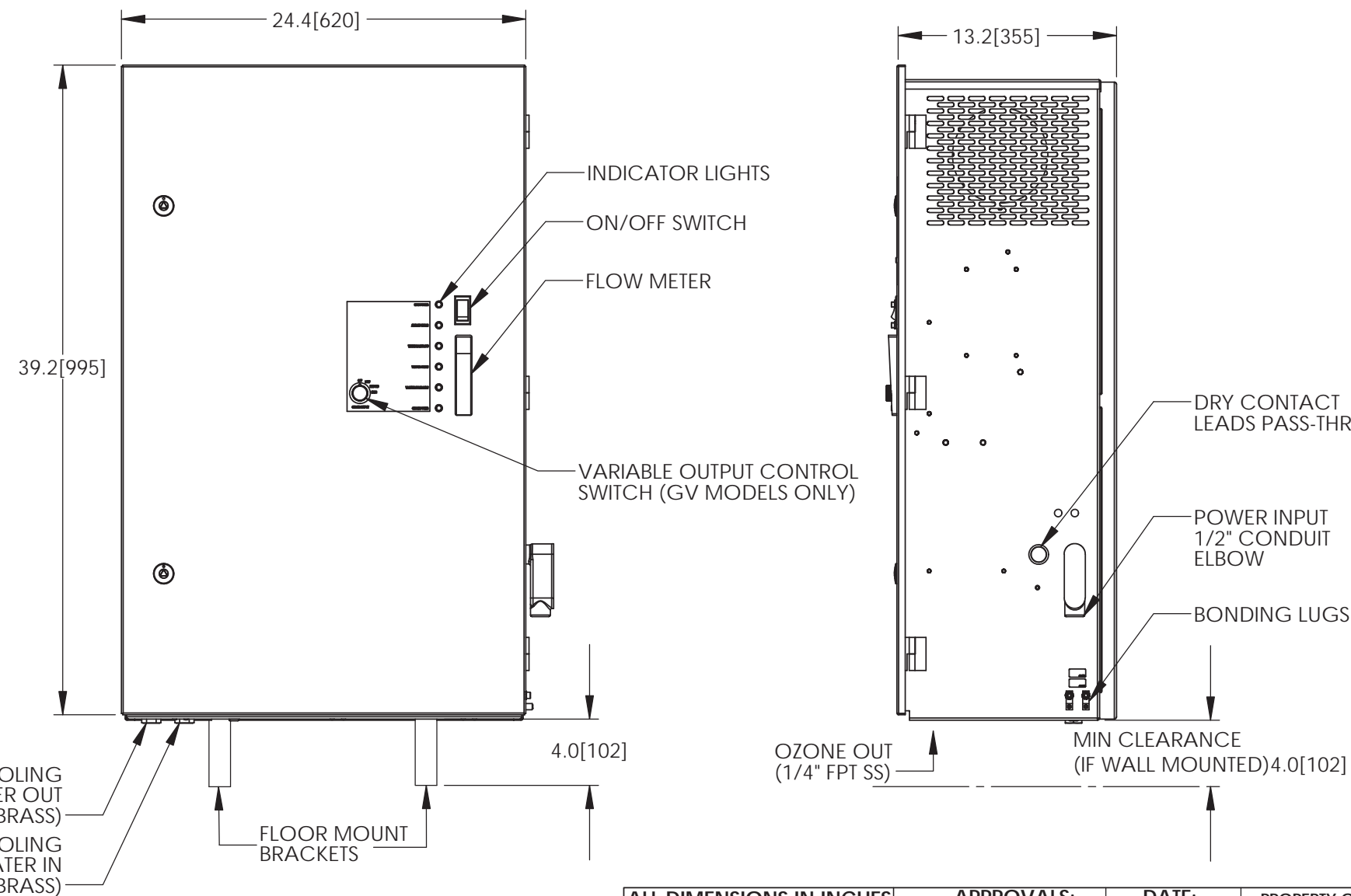
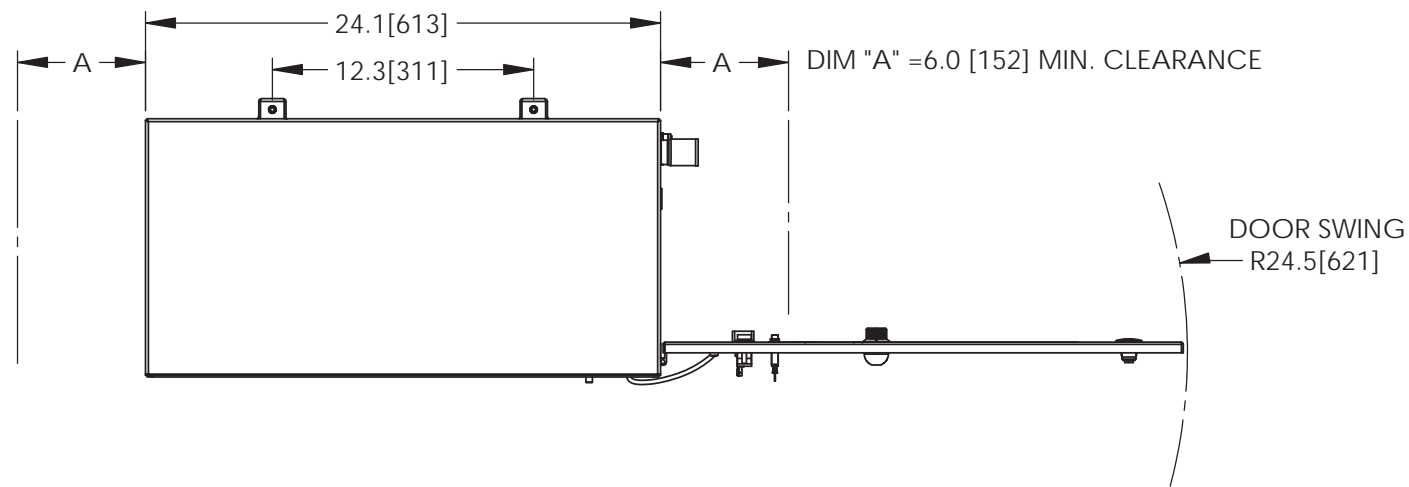

ALL DIMENSIONS IN INCHES [MM] TOLERANCES: .x ± .1 .xx ± .02 .xxx ± .010 ANGLES ± 1°		APPROVALS:	DATE:	PROPERTY OF DEL OZONE THIS DOCUMENT AND THE DATA DISCLOSED HEREIN IS PROPRIETARY. IT IS NOT TO BE REPRODUCED, USED, OR OTHERWISE DISCLOSED IN WHOLE, OR IN PART, TO ANYONE, WITHOUT WRITTEN CONSENT FROM DEL OZONE.		TITLE:						
		DRAWN: JBELL ENGR. APPR: Digitally signed by T.MCNEIL DN: cn=T.MCNEIL, o, ou, email=tmcneil@delozone.com, c=US Date: 2017.07.25 10:10:30 -07'00'	04/15/2013			SPECIFICATION_DRAWING CD-45GV-50						
ZONE	REV.	DESCRIPTION	ECN	DATE	CHECKED:	Q.A. APPR:	INTERPRET DRAWING PER ANSI Y14.5-1994	SCALE: 1:9 DO NOT SCALE DRAWING	SIZE: B	DWG. NO:	REV.:	SHEET:
		REVISIONS								4-1318-01	D	1 OF 1

D
C
B
A