

REVISIONS			
REV.	DESCRIPTION	ECN #	DATE
A	INITIAL RELEASE	NPI0105	05/24/2021

SPECIFICATIONS	
MODEL	AOP-PRO-50-XX
POWER	120 V / 2.2 A / 60 Hz
ENLCOSURE RATING	NEMA 12
AMBIENT OPERATING TEMP.	40 - 110 °F (5 - 43 °C)
OPERATING FLOW RANGE	20 -50 GPM
MAXIMUM OPERATING PRESSURE	50 PSI
MAXIMUM WATER TEMP.	102 °F (39 C)
APPROVALS	UL, NSF

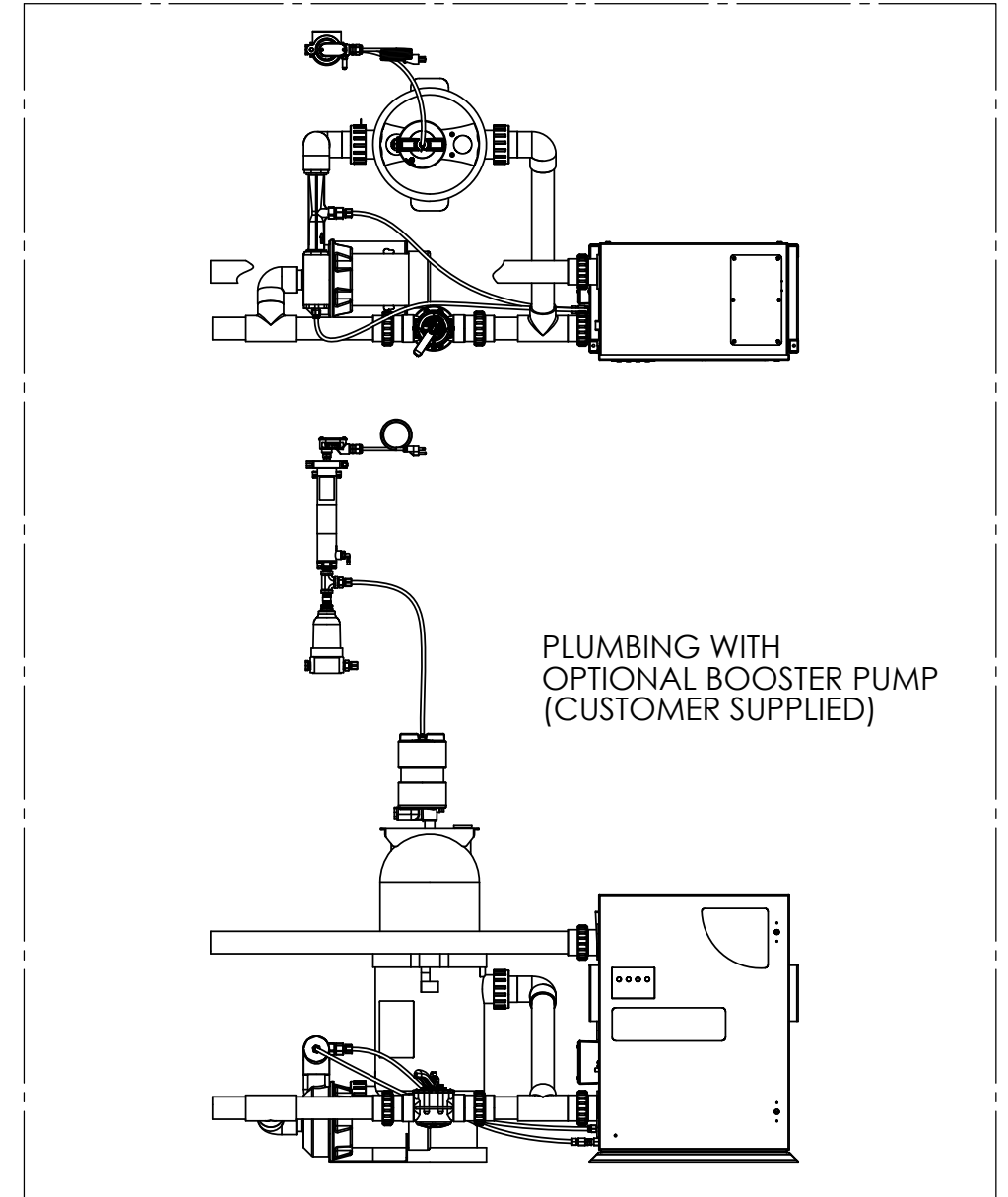
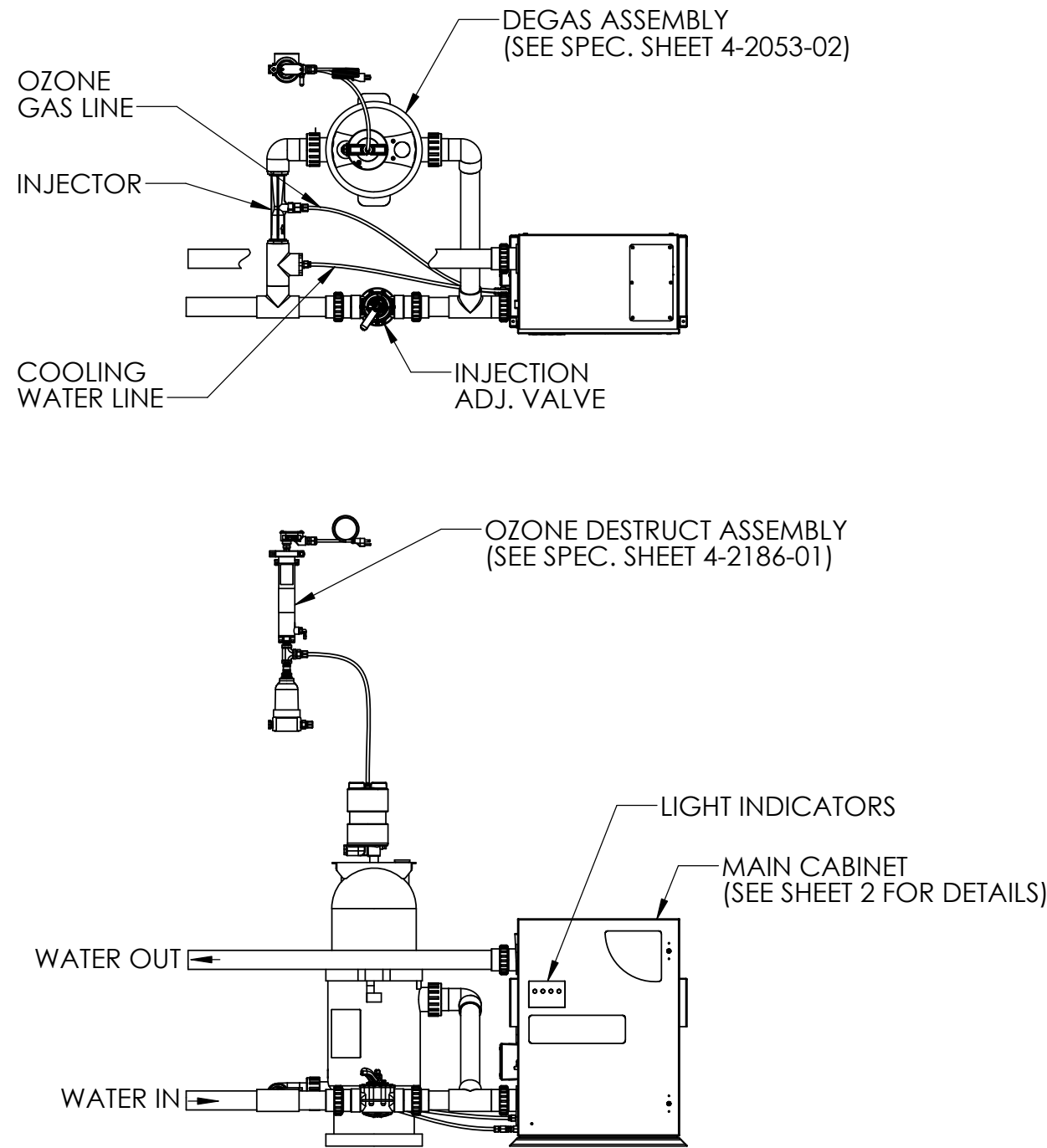

NOTES: UNLESS OTHERWISE SPECIFIED

1. AOP-PRO-50-01 MODEL SHOWN.
2. PVC PIPE NOT INCLUDED.

**PROPRIETARY AND CONFIDENTIAL**  
 THE INFORMATION CONTAINED IN THIS DRAWING IS THE SOLE PROPERTY OF CUSTOM MOLDED PRODUCTS. ANY REPRODUCTION IN PART OR AS A WHOLE WITHOUT THE WRITTEN PERMISSION OF CUSTOM MOLDED PRODUCTS IS PROHIBITED.

UNLESS OTHERWISE SPECIFIED DIMENSIONS ARE IN INCHES [mm]  
 TOLERANCES:  
 .X ± .1  
 .XX ± .02  
 .XXX ± .010  
 ANGLES: ± 1°

DRAWING STATE:	
PROJECT #/ECN #:	
ENGINEERING DESIGN	DATE
T.MCNEIL	5/24/2021
ENGINEERING APPROVAL	



TITLE: SPECIFICATION, DWG, AOP-PRO-50-XX

PART NO. 4-2658-01

REV A

MATERIAL NA  
 FINISH NA



CAD GENERATED DRAWING DO NOT MANUALLY UPDATE

SCALE: 1:20 DO NOT SCALE DRAWING

WEIGHT:

SHEET 1 OF 2

8 7 6 5 4 3 2 1

D  
C  
B  
A

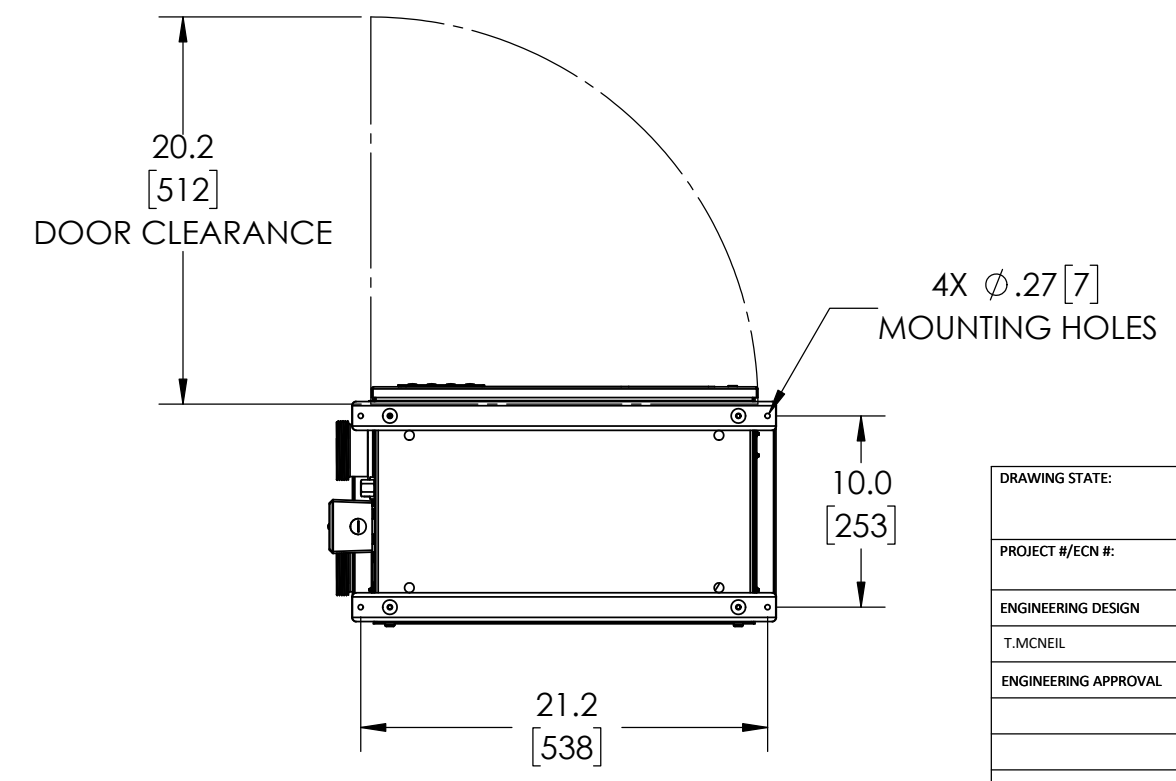
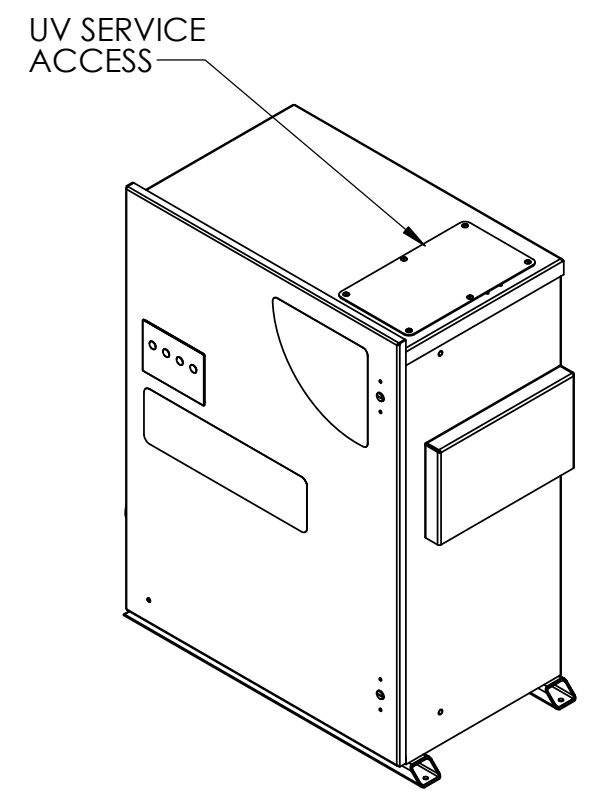
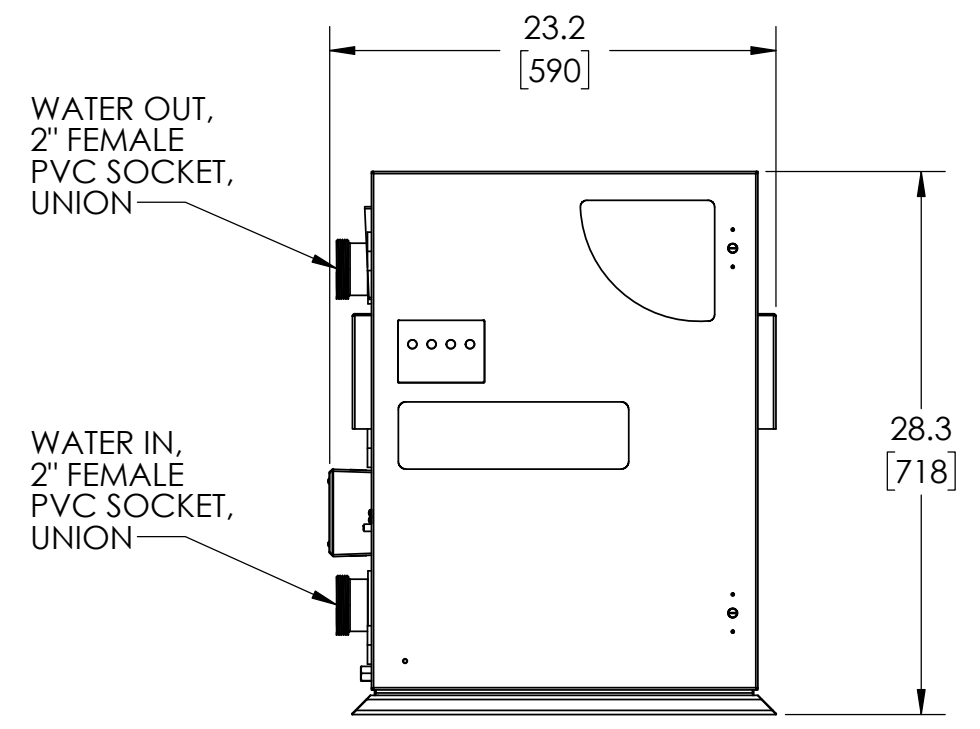
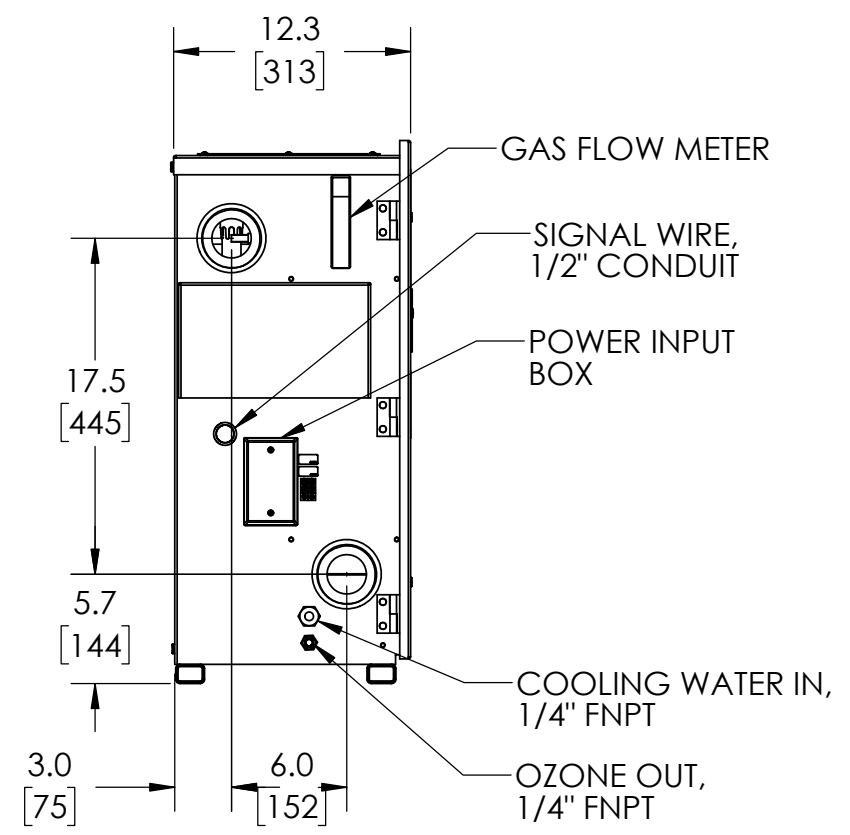

DRAWING STATE:		<b>CMP</b>	
PROJECT #/ECN #:			
ENGINEERING DESIGN	DATE	TITLE:	SPECIFICATION, DWG,
T.MCNEIL	5/24/2021	产品名称:	AOP-PRO-50-XX
ENGINEERING APPROVAL		PART NO.	4-2658-01
			REV <b>A</b>
CAD GENERATED DRAWING DO NOT MANUALLY UPDATE		SCALE: 1:20 DO NOT SCALE DRAWING	WEIGHT:
			SHEET 2 OF 2

8 3 2 1