

| REVISIONS |                 |         |            |
|-----------|-----------------|---------|------------|
| REV.      | DESCRIPTION     | ECN #   | DATE       |
| A         | INITIAL RELEASE | NPI0105 | 05/21/2021 |

| SPECIFICATIONS             |                         |
|----------------------------|-------------------------|
| MODEL                      | AOP-PRO-50DXX-XX        |
| POWER                      | 120 V / 2.7 A / 60 Hz   |
| ENLCOSURE RATING           | NEMA 12                 |
| AMBIENT OPERATING TEMP.    | 40 - 110 °F (5 - 43 °C) |
| OPERATING FLOW RANGE       | 20 -50 GPM              |
| MAXIMUM OPERATING PRESSURE | 50 PSI                  |
| MAXIMUM WATER TEMP.        | 102 °F (39 C)           |
| APPROVALS                  | UL, NSF                 |

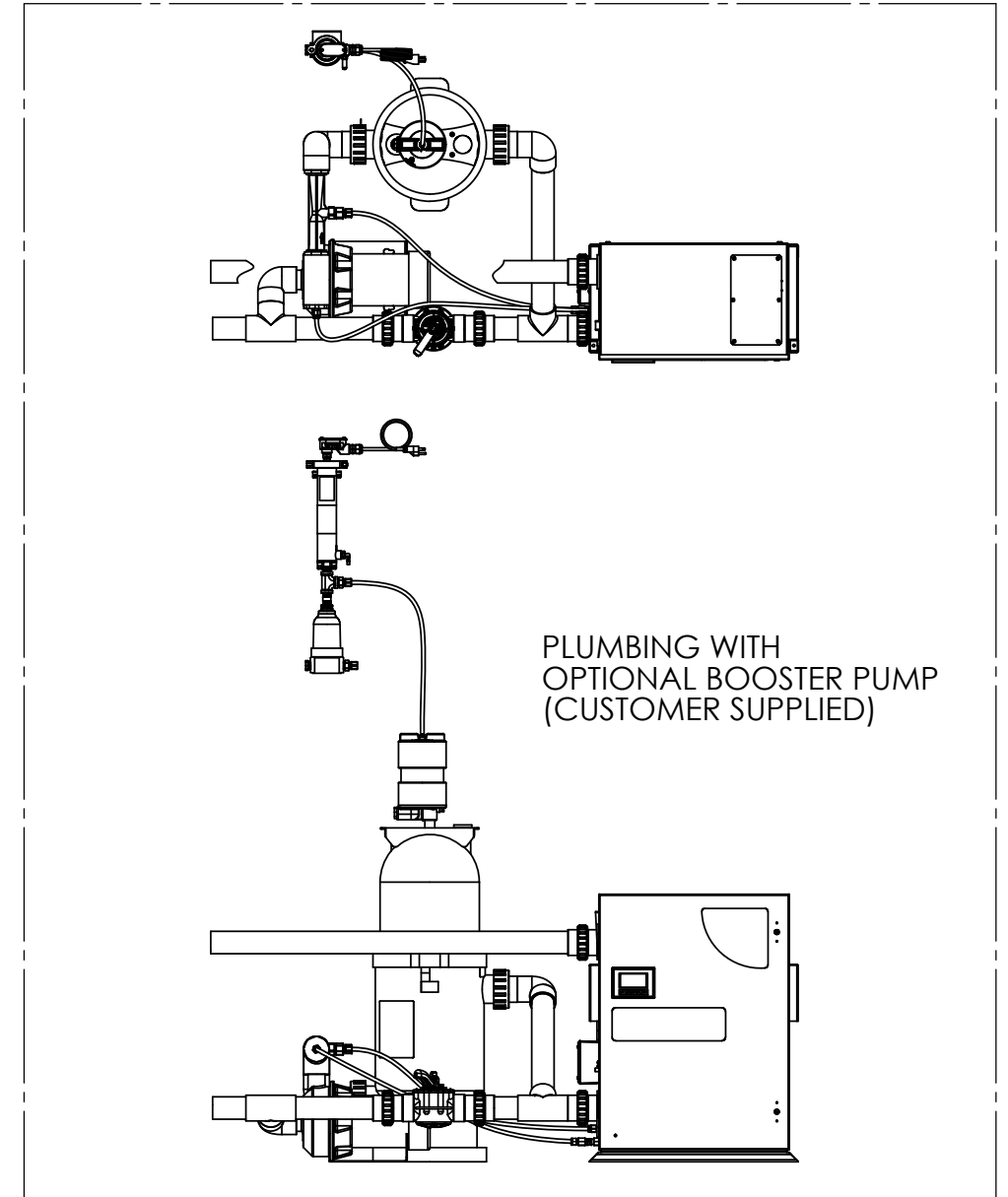
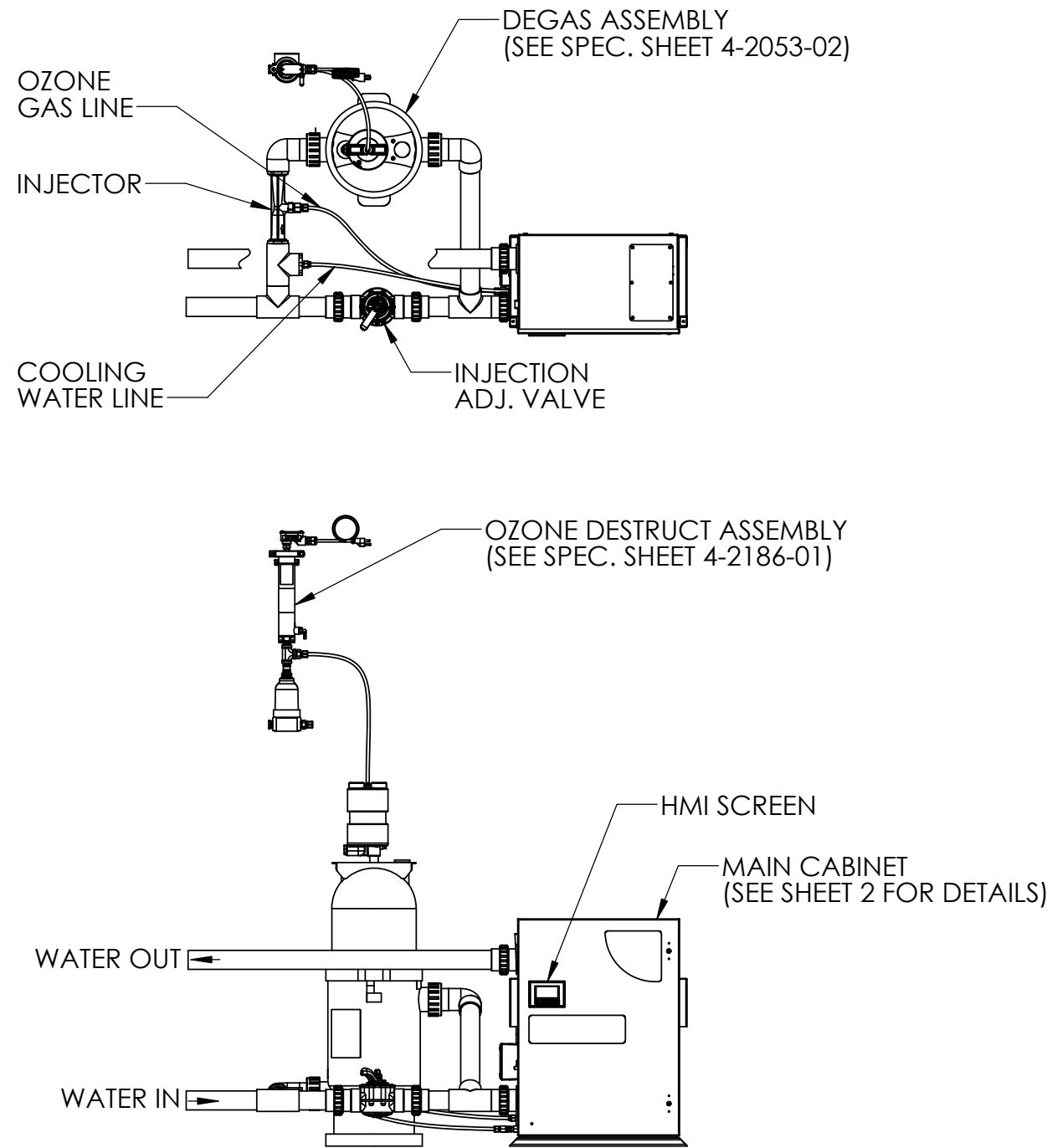

NOTES: UNLESS OTHERWISE SPECIFIED

1. AOP-PRO-50D-01 MODEL SHOWN.
2. PVC PIPE NOT INCLUDED.

**PROPRIETARY AND CONFIDENTIAL**  
 THE INFORMATION CONTAINED IN THIS DRAWING IS THE SOLE PROPERTY OF CUSTOM MOLDED PRODUCTS. ANY REPRODUCTION IN PART OR AS A WHOLE WITHOUT THE WRITTEN PERMISSION OF CUSTOM MOLDED PRODUCTS IS PROHIBITED.

UNLESS OTHERWISE SPECIFIED  
 DIMENSIONS ARE IN INCHES [mm]  
 TOLERANCES:  
 .X ± .1  
 .XX ± .02  
 .XXX ± .010  
 ANGLES: ± 1°

|                      |           |
|----------------------|-----------|
| DRAWING STATE:       |           |
| PROJECT #/ECN #:     |           |
| ENGINEERING DESIGN   | DATE      |
| T.MCNEIL             | 5/21/2021 |
| ENGINEERING APPROVAL |           |



TITLE: SPECIFICATION, DWG,  
 AOP-PRO-50DXX-XX

PART NO. 4-2658-02

REV  
**A**

|          |    |
|----------|----|
| MATERIAL | NA |
| FINISH   | NA |

CAD GENERATED DRAWING  
 DO NOT MANUALLY UPDATE

SCALE: 1:20  
 DO NOT SCALE DRAWING

WEIGHT:

SHEET 1 OF 2

8 7 6 5 4 3 2 1

D  
C  
B  
A

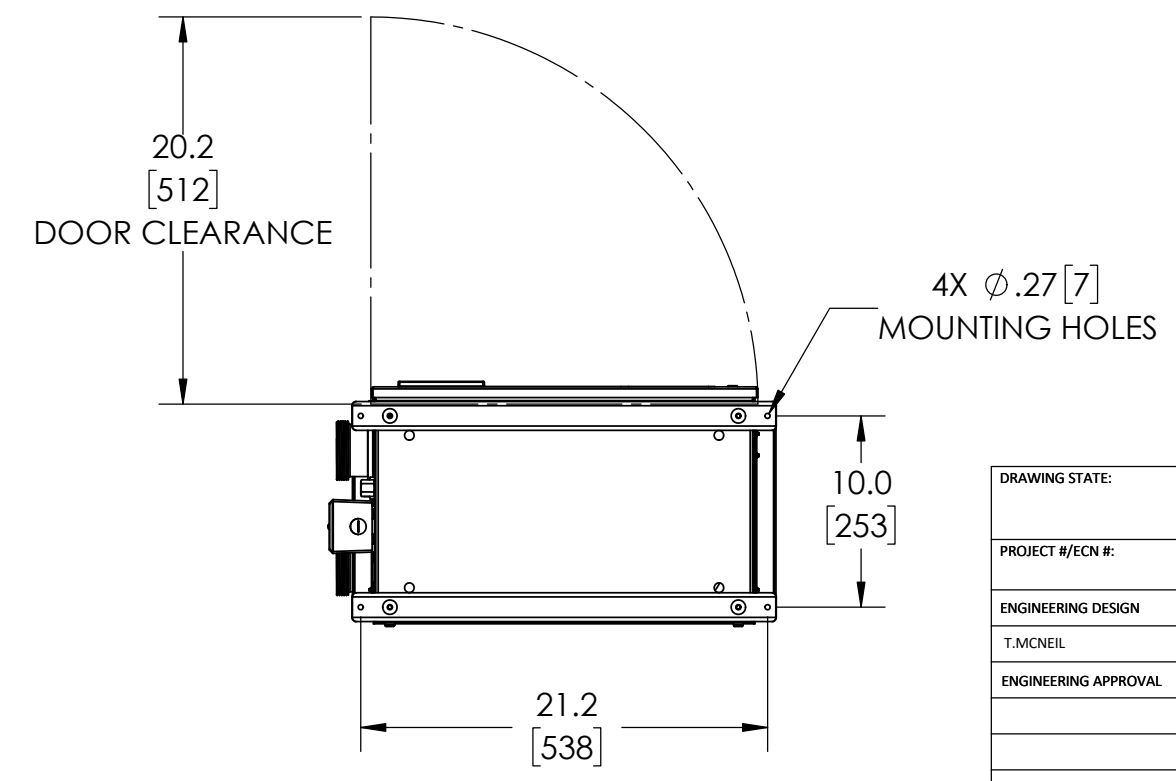
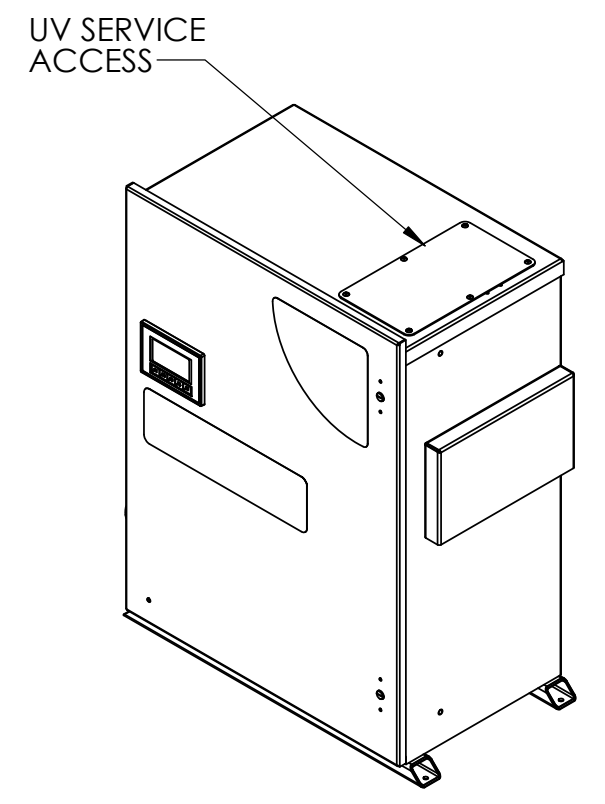
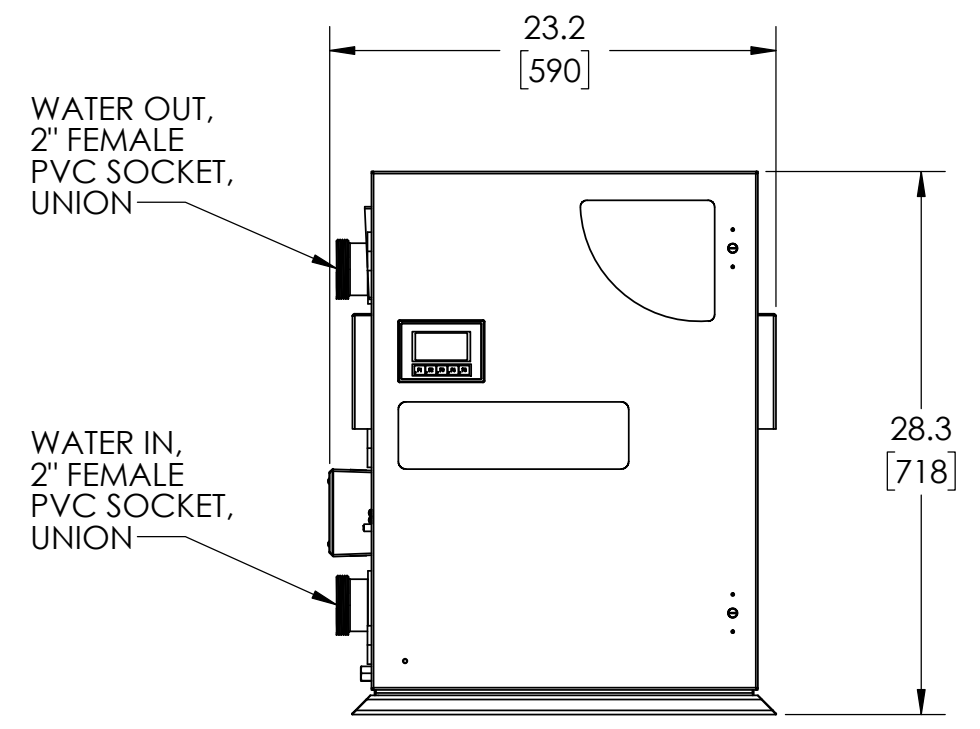
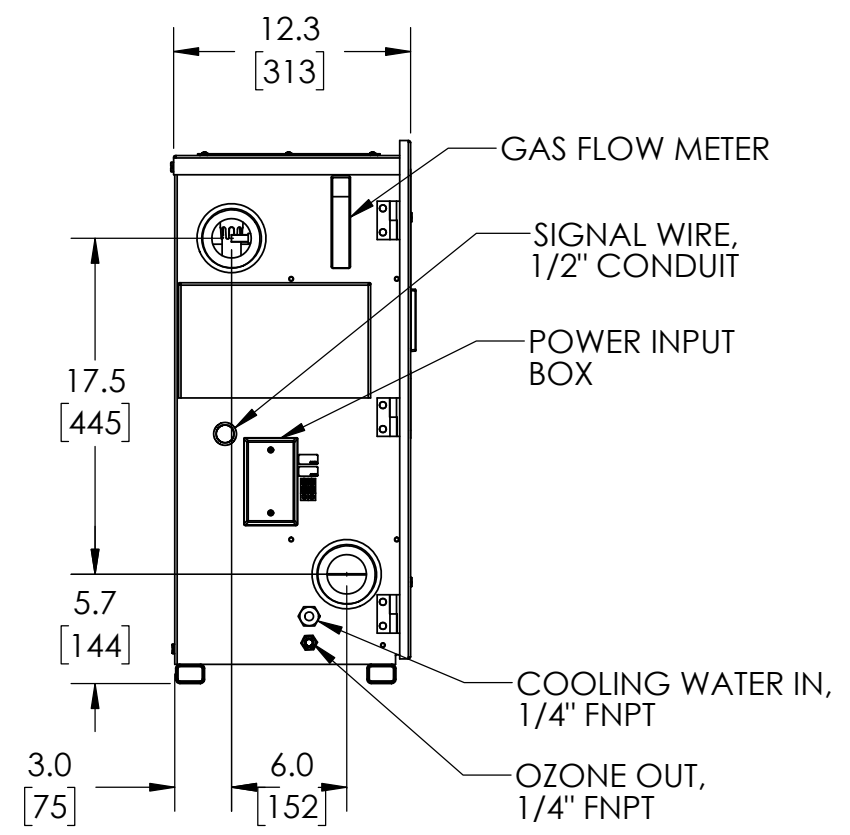

|   |           |                                     |                     |
|---|-----------|-------------------------------------|---------------------|
| DRAWING STATE:                                  |           | <b>CMP</b>                          |                     |
| PROJECT #/ECN #:                                |           |                                     |                     |
| ENGINEERING DESIGN                              | DATE      | TITLE:                              | SPECIFICATION, DWG, |
| T.MCNEIL  | 5/21/2021 | 产品名称:                               | AOP-PRO-50DXX-XX    |
| ENGINEERING APPROVAL                            |           | PART NO.                            | 4-2658-02           |
|   |           |                                     | REV<br><b>A</b>     |
| CAD GENERATED DRAWING<br>DO NOT MANUALLY UPDATE |           | SCALE: 1:20<br>DO NOT SCALE DRAWING | WEIGHT:             |
|   |           |                                     | SHEET 2 OF 2        |

8 3 2 1