

| REVISIONS |                 |         |           |
|-----------|-----------------|---------|-----------|
| REV.      | DESCRIPTION     | ECN #   | DATE      |
| A         | INITIAL RELEASE | NPI0105 | 4/28/2021 |

| SPECIFICATIONS             |                         |
|----------------------------|-------------------------|
| MODEL                      | AOP-PRO-350DXX-XX       |
| POWER                      | 240 V / 7.8 A / 60 Hz   |
| ENCLOSURE RATING           | NEMA 12                 |
| AMBIENT OPERATING TEMP.    | 40 - 100 °F (5 - 38 °C) |
| OPERATING FLOW RANGE       | 125 - 350 GPM           |
| MAXIMUM OPERATING PRESSURE | 50 PSI                  |
| MAXIMUM WATER TEMP.        | 102 °F (39 °C)          |
| APPROVALS                  | UL, NSF                 |

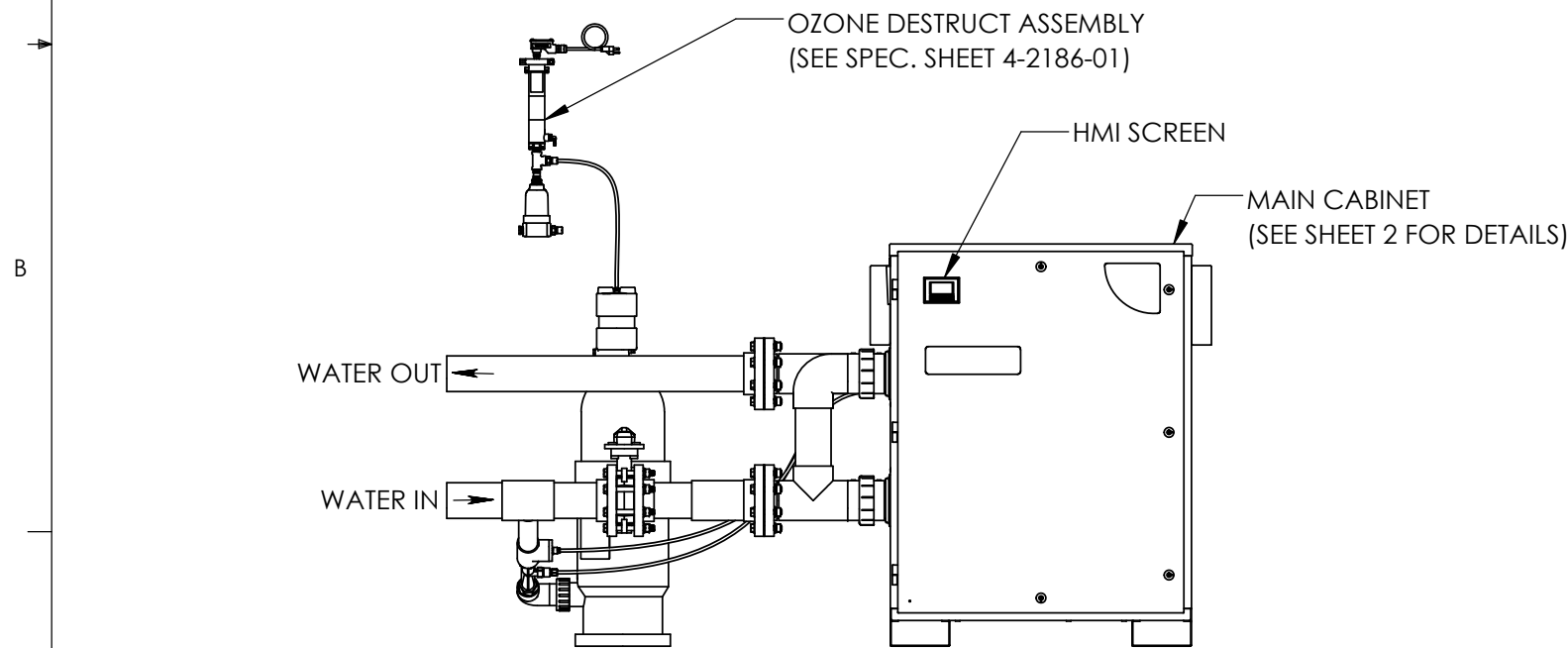
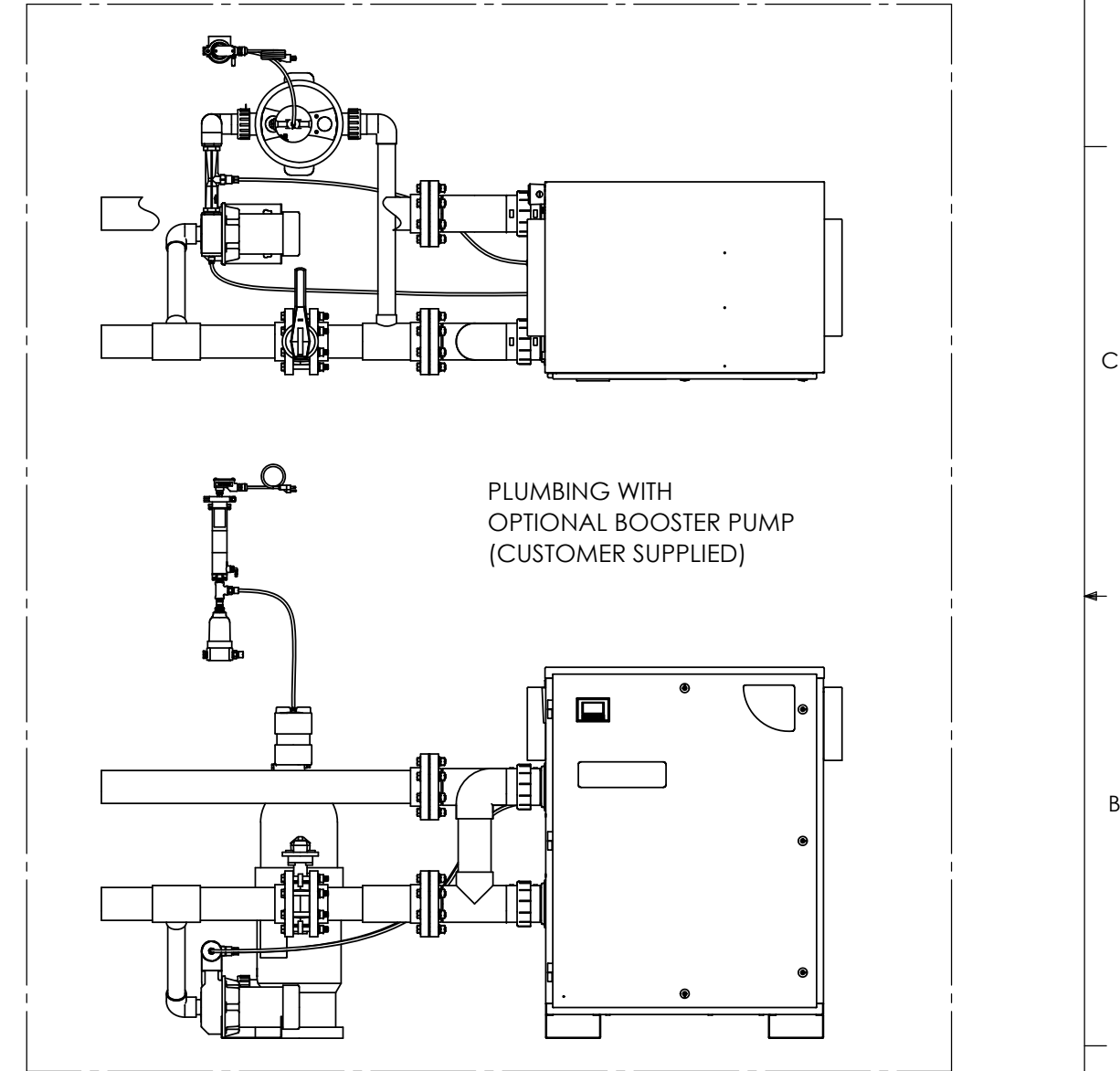
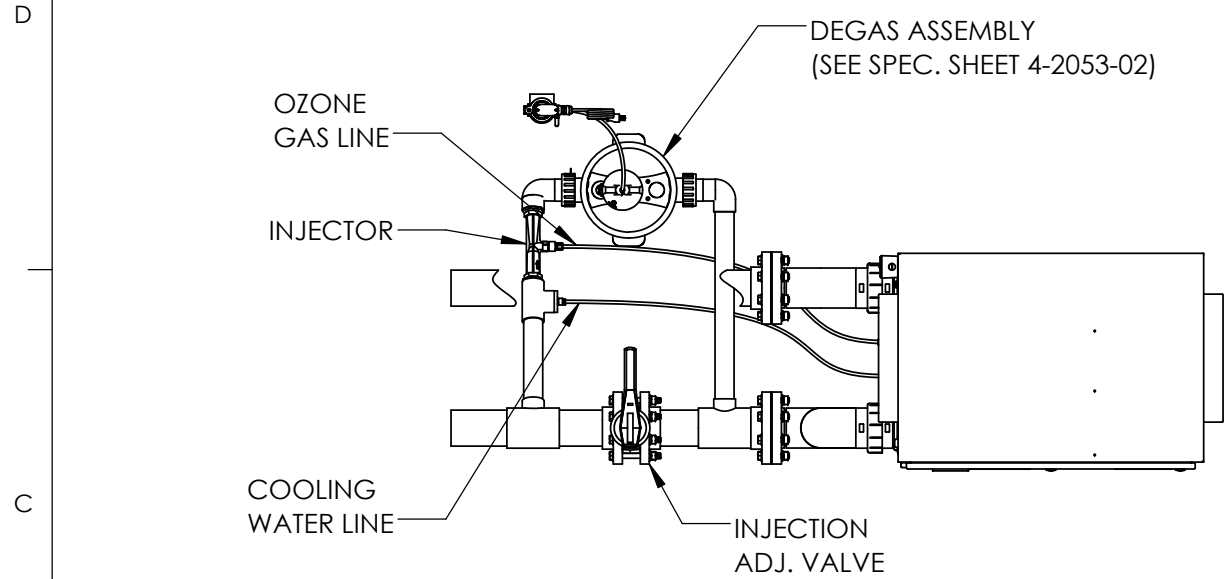

NOTES: UNLESS OTHERWISE SPECIFIED

- AOP-PRO-350D-01 MODEL SHOWN.
- PVC PIPE NOT INCLUDED.

**PROPRIETARY AND CONFIDENTIAL**  
THE INFORMATION CONTAINED IN THIS DRAWING IS THE SOLE PROPERTY OF CUSTOM MOLDED PRODUCTS. ANY REPRODUCTION IN PART OR AS A WHOLE WITHOUT THE WRITTEN PERMISSION OF CUSTOM MOLDED PRODUCTS IS PROHIBITED.

UNLESS OTHERWISE SPECIFIED  
DIMENSIONS ARE IN INCHES [mm]  
TOLERANCES:  
X ± .1  
XX ± .02  
XXX ± .010

ANGLES: ± 1°

DRAWING STATE:

PROJECT #/ECN #:

ENGINEERING DESIGN

DATE

T.MCNEIL

4/28/2021

ENGINEERING APPROVAL



TITLE: SPECIFICATION, DWG,  
AOP-PRO-350DXX-XX

PART NO.

4-2658-08

REV

A

SCALE: 1:16  
DO NOT SCALE DRAWING

WEIGHT:

SHEET 1 OF 2

MATERIAL  
NA  
FINISH  
NA



CAD GENERATED DRAWING  
DO NOT MANUALLY UPDATE

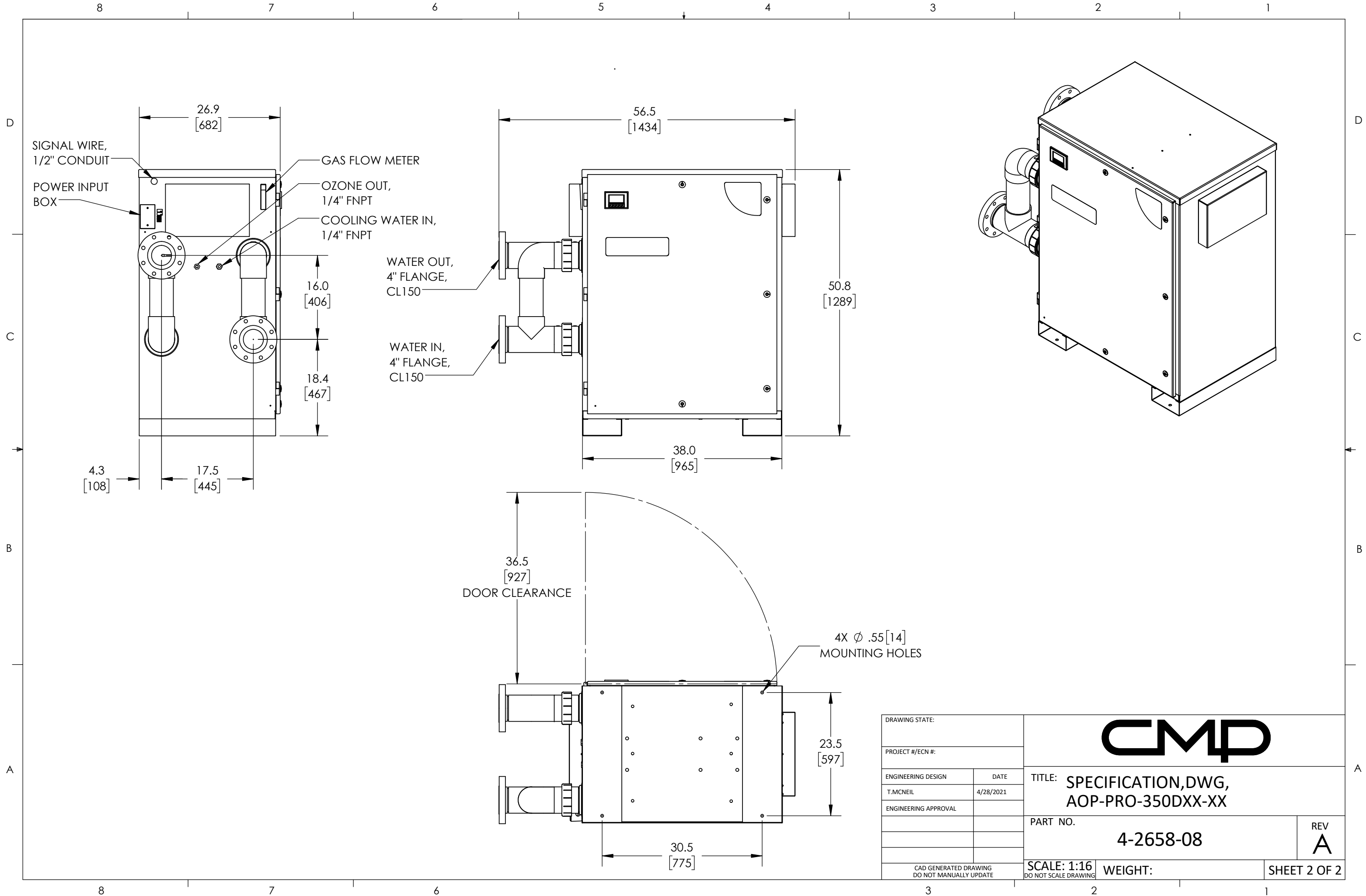

|   |           |
|---|-----------|
| DRAWING STATE:                                  |           |
| PROJECT #/ECN #:                                |           |
| ENGINEERING DESIGN                              | DATE      |
| T.MCNEIL  | 4/28/2021 |
| ENGINEERING APPROVAL                            |           |
|   |           |
|   |           |
| CAD GENERATED DRAWING<br>DO NOT MANUALLY UPDATE |           |

|   |         |
|---|---------|
| <b>CMP</b>                                      |         |
| TITLE: SPECIFICATION, DWG,<br>AOP-PRO-350DXX-XX |         |
| PART NO.  |         |
| <b>4-2658-08</b>                                |         |
| REV   |         |
| <b>A</b>  |         |
| SCALE: 1:16<br>DO NOT SCALE DRAWING             | WEIGHT: |
| SHEET 2 OF 2                                    |         |