

REVISIONS			
REV.	DESCRIPTION	ECN #	DATE
A	INITIAL RELEASE	NPI0105	5/26/2021

SPECIFICATIONS	
MODEL	UVC-PRO-50-XX
POWER	120 V / 1.1 A / 60 Hz
ENCLOSURE RATING	NEMA 12
AMBIENT OPERATING TEMP.	40 - 110 °F (5 - 43 °C)
OPERATING FLOW RANGE	20 - 50 GPM
MAXIMUM OPERATING PRESSURE	50 PSI
MAXIMUM WATER TEMP.	102 °F (39 C)
APPROVALS	UL, NSF

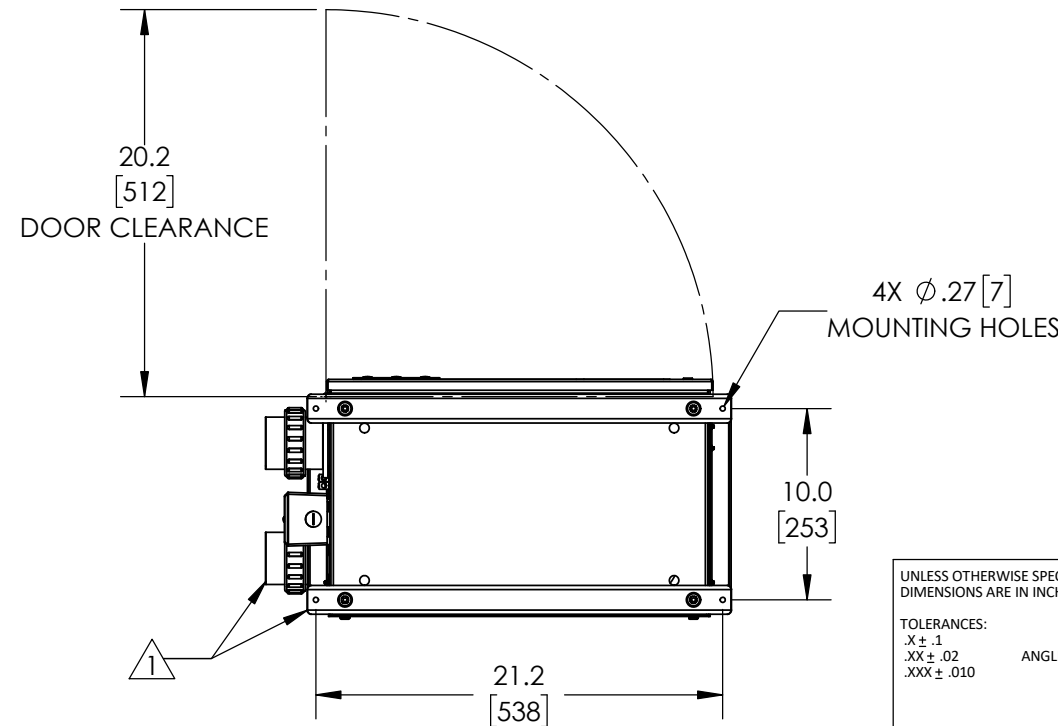
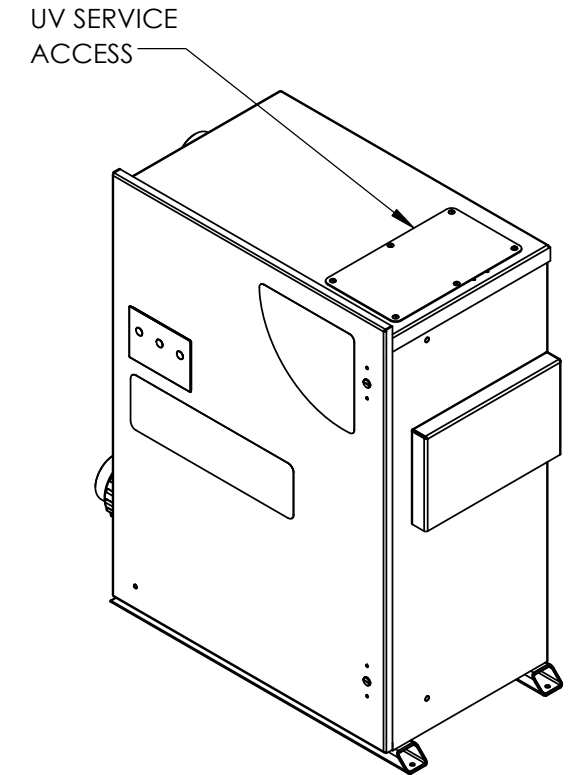
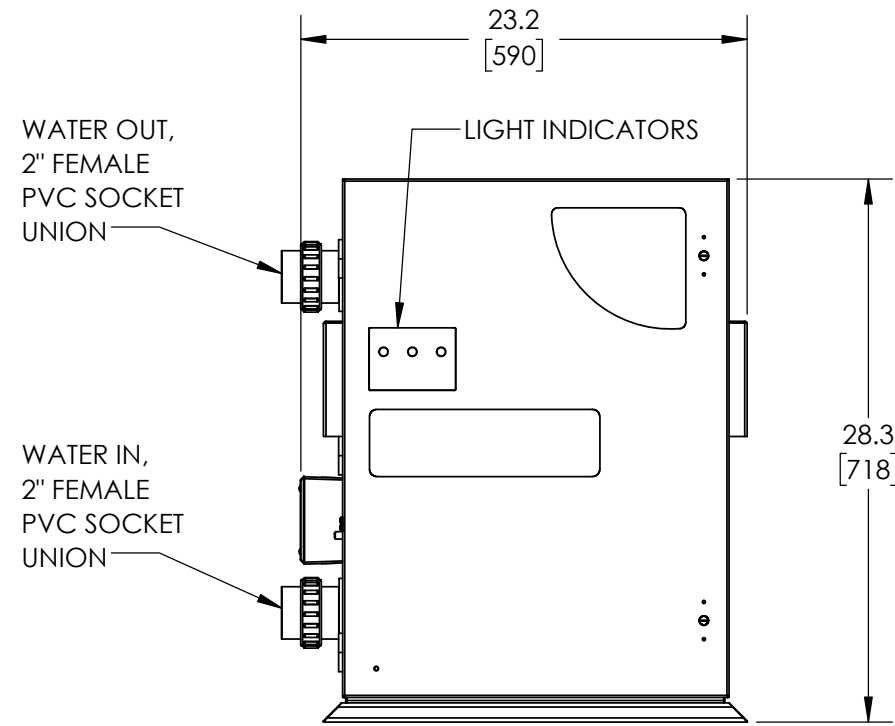
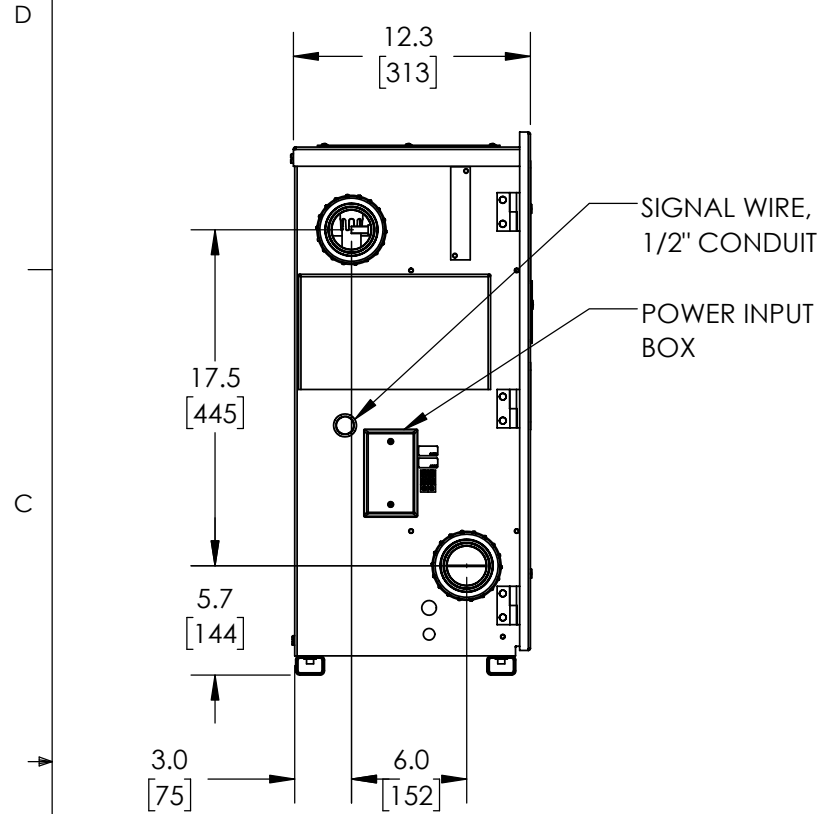

NOTES: UNLESS OTHERWISE SPECIFIED

1 2" FEMALE PVC SOCKET UNIONS AND FLOOR/WALL MOUNTING BRACKETS INCLUDED IN PARTS KIT.

2. UVC-PRO-50-01 MODEL SHOWN.

PROPRIETARY AND CONFIDENTIAL
 THE INFORMATION CONTAINED IN THIS DRAWING IS THE SOLE PROPERTY OF CUSTOM MOLDED PRODUCTS. ANY REPRODUCTION IN PART OR AS A WHOLE WITHOUT THE WRITTEN PERMISSION OF CUSTOM MOLDED PRODUCTS IS PROHIBITED.

UNLESS OTHERWISE SPECIFIED DIMENSIONS ARE IN INCHES [mm]
 TOLERANCES:
 X ± .1
 XX ± .02
 XXX ± .010
 ANGLES: ± 1°

DRAWING STATE:	
PROJECT #/ECN #:	
ENGINEERING DESIGN	DATE
T.MCNEIL	5/26/2021
ENGINEERING APPROVAL	



TITLE: SPECIFICATION, DWG,
 UVC-PRO-50-XX

PART NO.
 4-2696-01

REV
 A

MATERIAL
 NA
 FINISH
 NA

CAD GENERATED DRAWING
 DO NOT MANUALLY UPDATE

SCALE: 1:10
 DO NOT SCALE DRAWING

WEIGHT:

SHEET 1 OF 1