

REVISIONS			
REV.	DESCRIPTION	ECN #	DATE
A	INITIAL RELEASE	NPI0105	05/05/2021

SPECIFICATIONS	
MODEL	UVC-PRO-350DXX-XX
POWER	240 V / 3.4 A / 60 Hz
ENCLOSURE RATING	NEMA 12
AMBIENT OPERATING TEMP.	40 - 110 °F (5 - 43 °C)
OPERATING FLOW RANGE	125 - 350 GPM
MAXIMUM OPERATING PRESSURE	50 PSI
MAXIMUM WATER TEMP.	102 °F (39 °C)
APPROVALS	UL, NSF

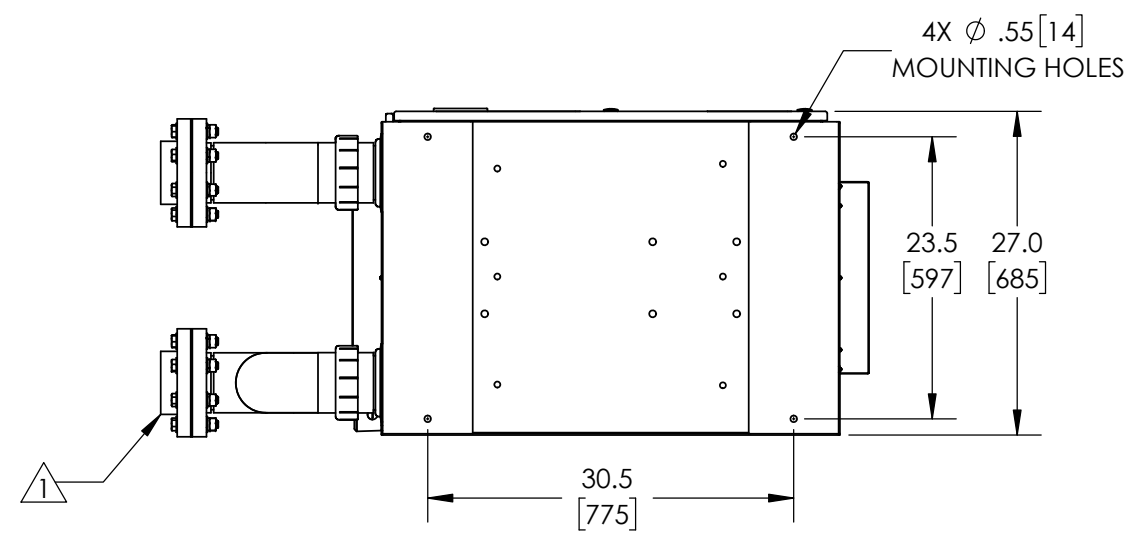
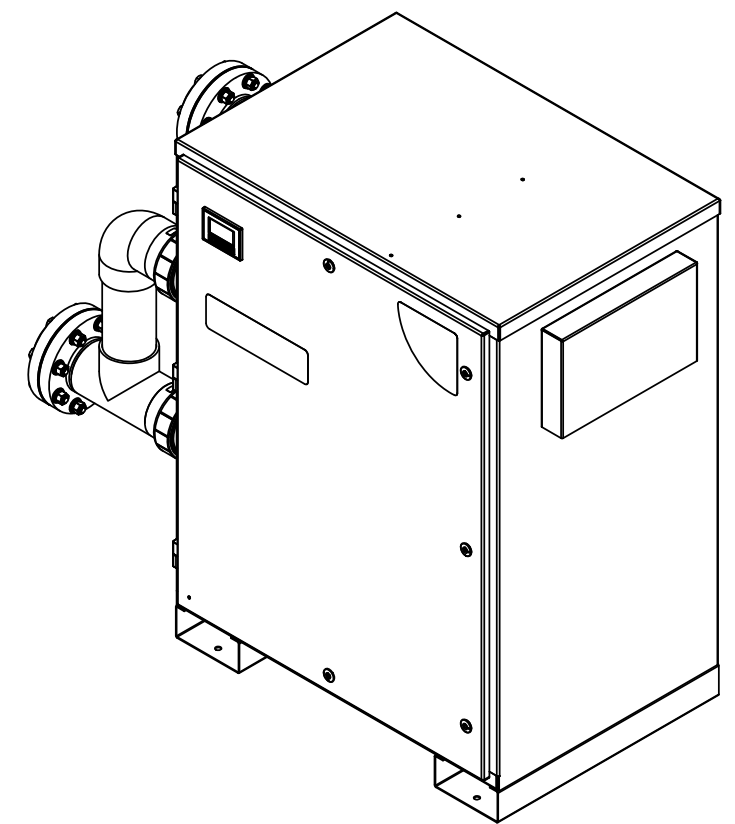
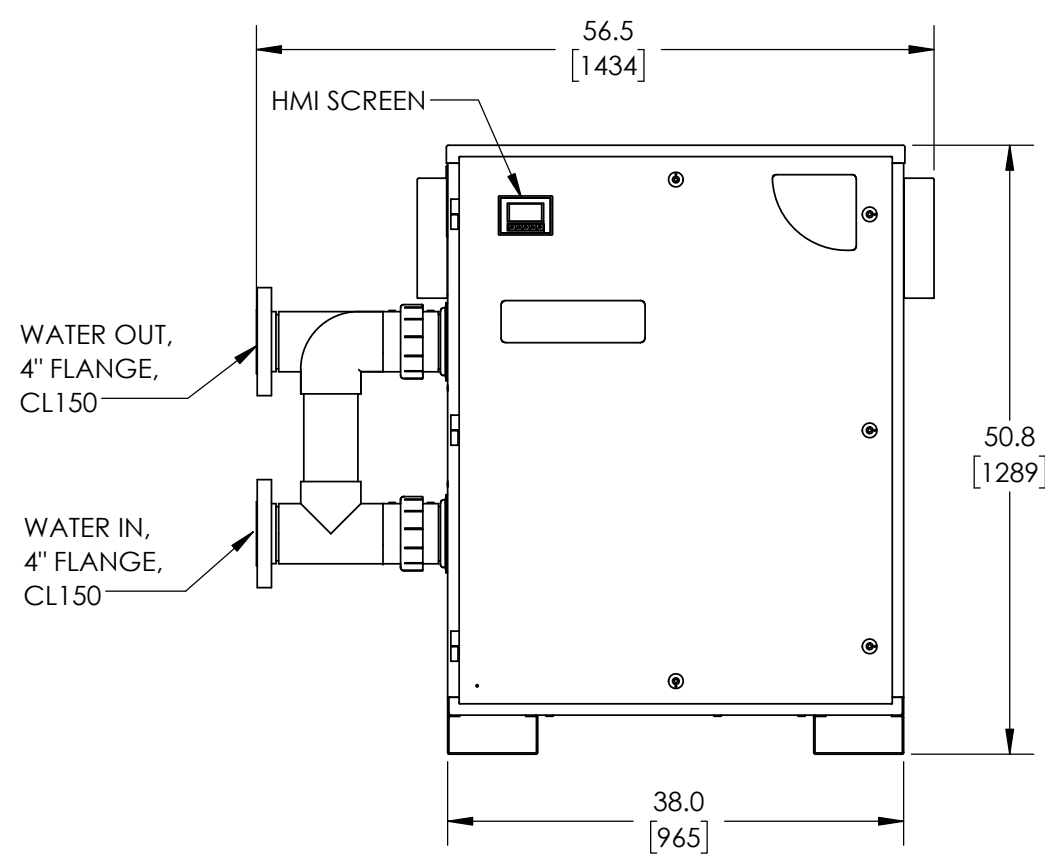
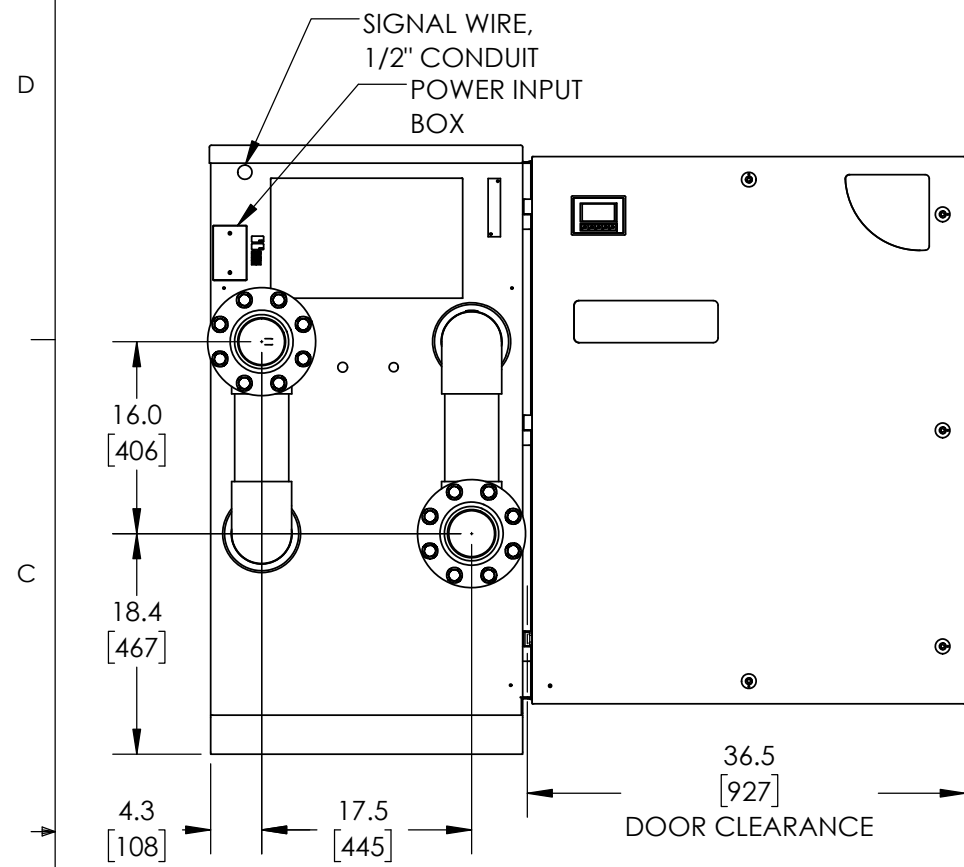

NOTES: UNLESS OTHERWISE SPECIFIED

① 4" FEMALE PVC SOCKET FLANGES, FLANGE GASKETS AND HARDWARE INCLUDED IN PARTS KIT.

2. UVC-PRO-350D-01 MODEL SHOWN.

UNLESS OTHERWISE SPECIFIED DIMENSIONS ARE IN INCHES [mm]
 TOLERANCES:
 X ± .1
 .XX ± .02
 .XXX ± .010
 ANGLES: ± 1°

DRAWING STATE:	
PROJECT #/ECN #:	
ENGINEERING DESIGN	DATE
T.MCNEIL	5/5/2021
ENGINEERING APPROVAL	

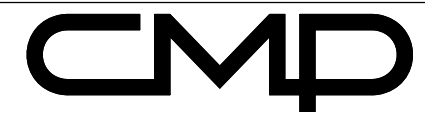

TITLE: SPECIFICATION, DWG, UVC-PRO-350DXX-XX	
PART NO. 4-2696-08	REV A
SCALE: 1:16 DO NOT SCALE DRAWING	WEIGHT:
SHEET 1 OF 1	

PROPRIETARY AND CONFIDENTIAL
 THE INFORMATION CONTAINED IN THIS DRAWING IS THE SOLE PROPERTY OF CUSTOM MOLDED PRODUCTS. ANY REPRODUCTION IN PART OR AS A WHOLE WITHOUT THE WRITTEN PERMISSION OF CUSTOM MOLDED PRODUCTS IS PROHIBITED.

MATERIAL NA
FINISH NA

CAD GENERATED DRAWING
DO NOT MANUALLY UPDATE