

DD-0650-01 SHOWN FOR REFERENCE

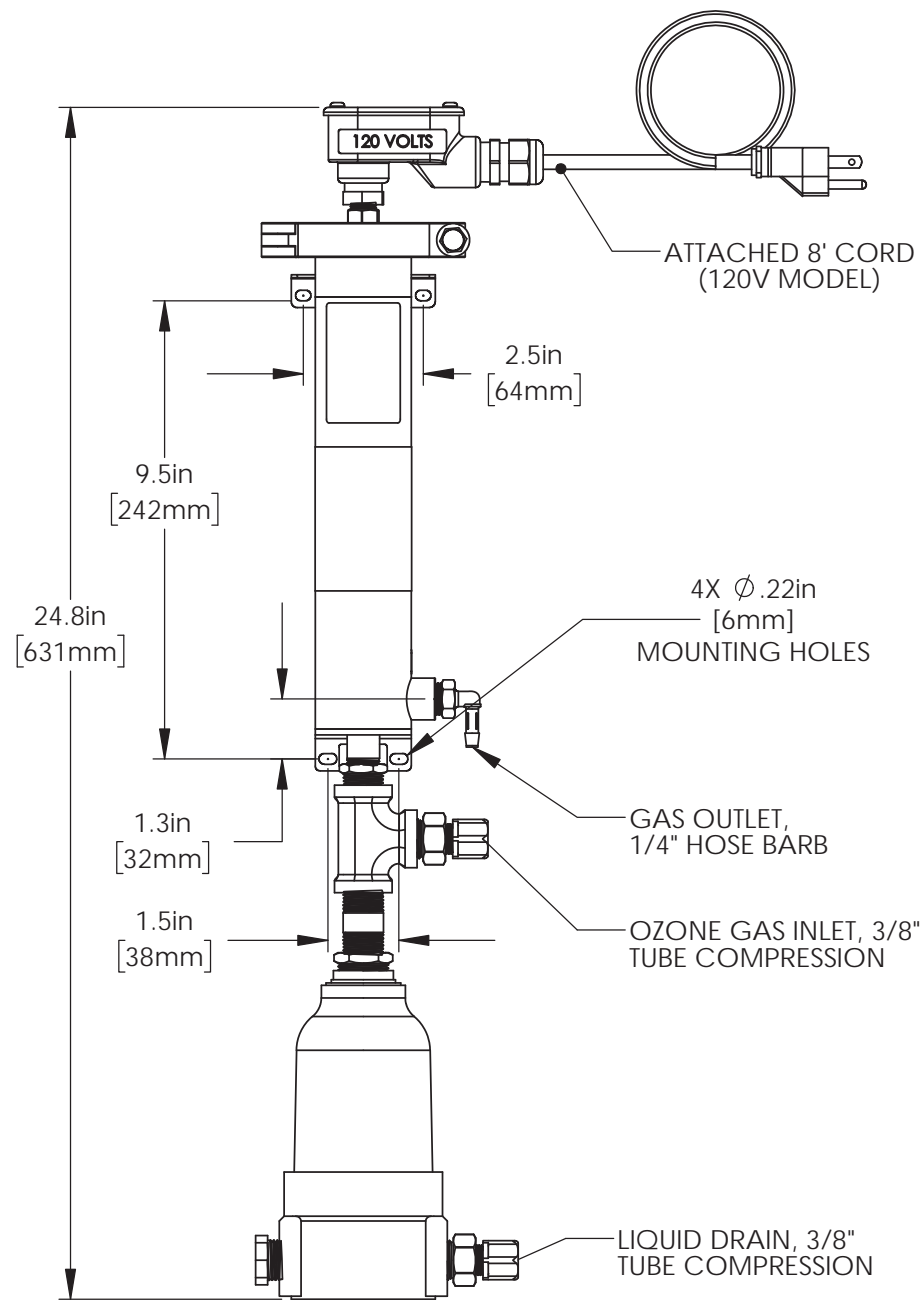

9-1140-50 SHOWN FOR REFERENCE

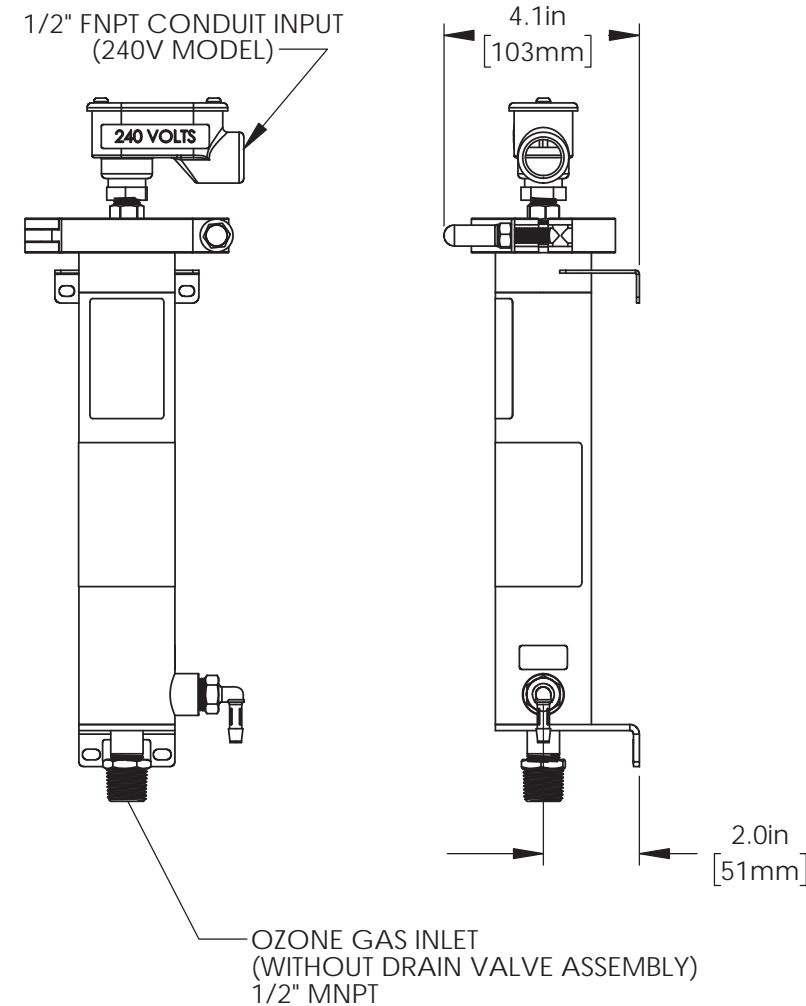

MODEL GUIDE	VOLTAGE	
	120V	240V
COMPLETE DESTRUCT	DD-0650-01	DD-0650-50
WITHOUT DRAIN VALVE ASSEMBLY	9-1140-01	9-1140-50
DRAIN VALVE ASSEMBLY	9-1145-01	

SPECIFICATIONS:

- POWER----- 120 OR 240 VAC (DEPENDING ON MODEL)
50/60Hz
- POWER CONSUMPTION-----10 VA
- ELECTRICAL CONNECTION----NEMA 5-15P (120V) OR HARDWIRED
W/CONDUIT (240V)
- DESTRUCT TECHNOLOGY----THERMAL CATALYTIC
- RATED GAS FLOW----- 65 SCFH @ 7.5% O3 BY WEIGHT*
- GAS HUMIDITY----- 0-100% RH
- MATERIAL----- STAINLESS STEEL
- WEIGHT----- 5.5 LBS WITH DRAIN VALVE ASSEMBLY
4.5 LBS WITHOUT DRAIN VALVE ASSEMBLY

* FOR <100 PPB AT DESTRUCT OUTLET

FLOW CHARACTERISTICS
(MEASURED WITH DRAIN VALVE ASSEMBLY)

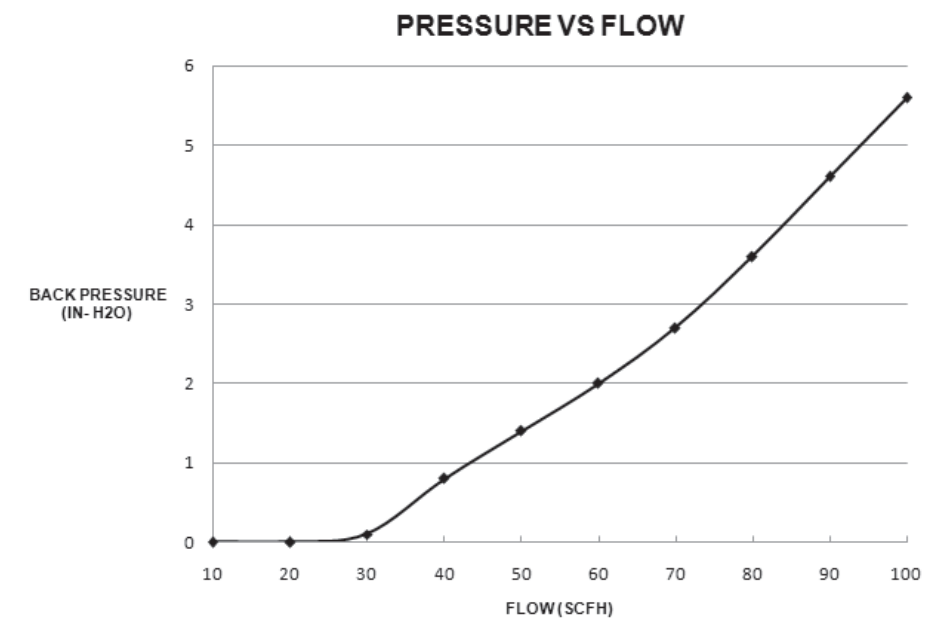

ALL DIMENSIONS IN INCHES [mm]				APPROVALS:		DATE:		PROPERTY OF DEL OZONE		TITLE:	
TOLERANCES:				DRAWN:		7/1/2014		THIS DOCUMENT AND THE DATA DISCLOSED HEREIN IS PROPRIETARY. IT IS NOT TO BE REPRODUCED, USED, OR OTHERWISE DISCLOSED IN WHOLE, OR IN PART, TO ANYONE, WITHOUT WRITTEN CONSENT FROM DEL OZONE.		SPECIFICATION, DRAWING, MEDIUM_DESTRUCT	
.x ± .1 .xx ± .02 .xxx ± .010				J. WILSON		ENGR. APPR: Digitally signed by T.MCNEIL DN: cn=T.MCNEIL, o=ou, email=tmcneil@delozone.com, c=US Date: 2017.10.20 09:42:18 -07'00'					
MATERIAL: NA				CHECKED:				DEL OZONE advanced sanitation solutions		DWG. NO:	
FINISH: NA				Q.A. APPR:				INTERPRET DRAWING PER ANSI Y14.5-1994		REV. SHEET:	
								SCALE: 1:8		C 1 OF 1	
								DO NOT SCALE DRAWING		4-2186-01	

ZONE	REV.	DESCRIPTION	ECN	DATE
	C	SHOW NEW DRAIN VALVE ASSEMBLY ORIENTATION	6003	08/24/2017
	B	ADD BARBED FITTING TO OUTLET	5543	6/4/2015
	A	INITIAL PRODUCTION RELEASE	5294	7/1/2014
REVISIONS				

D
C
B
A
B FORMAT REV A