

INTERNAL PLUMBING VIEW

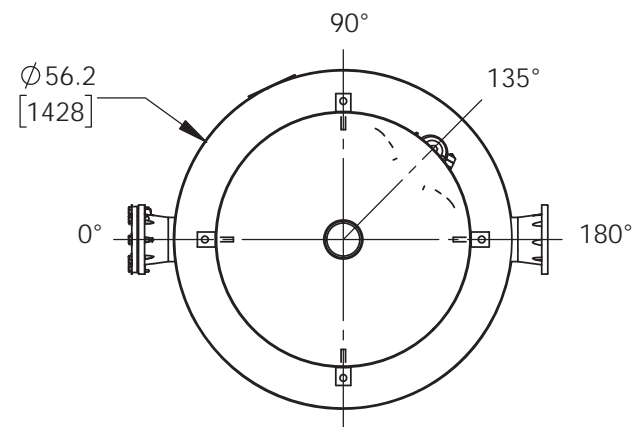

BOTTOM VIEW

SPECIFICATIONS	
MODEL	7-CT-0800-01
MATERIALS	TANK: HIGH STRENGTH FIBERGLASS, VINYL ESTER RESIN, REINFORCED CORROSION RESISTANT LINER INTERNAL PLUMBING: SCH 80 PVC ¹ HARDWARE: 316 SS
PRESSURE	50 PSI WORKING PRESSURE WITH 4:1 SAFETY FACTOR
SEISMIC	ZONE 4
AGENCY	NSF/ANSI STANDARD 50

NOTES

- ¹. DEL PROPRIETARY INTERNAL BAFFLING TO MEET NSF CONTACTING REQUIREMENTS.
- ². LIFTING LUGS TO BE USED ONLY WITH EMPTY TANK.

ALL DIMENSIONS IN INCHES		APPROVALS:	DATE:	PROPERTY OF DEL OZONE THIS DOCUMENT AND THE DATA DISCLOSED HEREIN IS PROPRIETARY. IT IS NOT TO BE REPRODUCED, USED, OR OTHERWISE DISCLOSED IN WHOLE, OR IN PART, TO ANYONE, WITHOUT WRITTEN CONSENT FROM DEL OZONE.	 DEL ozone advanced sanitation solutions	TITLE:			
TOLERANCES:		DRAWN:	7/29/2014			SPEC_DRAWING,O3_CONTACT_TANK,800GAL,55"DIA			
.x ± .2 .xx ± .02 .xxx ± .010		ENGR. APPR:				DWG. NO:			
ANGLES ± 1°		Frank Martin				REV. SHEET:			
MATERIAL:		CHECKED:		SCALE: 1:32		B INTERPRET DRAWING PER ANSI Y14.5-1994 DO NOT SCALE DRAWING	4-1767-14		C 1 OF 1
FINISH:		Q.A. APPR:		DO NOT SCALE DRAWING			REV. SHEET:		

ZONE	REV.	DESCRIPTION	ECN	DATE
	C	UPDATE WITH NEW MANWAY COVER ON TOP AND DRAIN	ECN01708	03/21/2019
	B	CHANGE INLET AND OUTLET	5393	11/12/2014
REVISIONS				

D
C
B
A
B FORMAT REV A